



## Description

The KSIC CO<sub>2</sub> room sensor measures air quality through the presence of carbon dioxide in the range between 0 and 10k ppm. The measurement of CO<sub>2</sub> concentration happens through a maintenance free NDIR sensor that operates on an infrared basis and which compensates the presence of any impurity. The product is provided different outputs.

## Technical specifications

<b>Measurement range CO<sub>2</sub></b>	400...2000, 0...2k, 0...5k, 0...10k ppm selectable
<b>Accuracy CO<sub>2</sub></b>	± 70 ppm +3% reading
<b>Accuracy temperature (*)</b>	±0,3°C (5...60°C) + 1% FS
<b>Accuracy humidity (*)</b>	±2% RH (20...80%RH) + 2% FS
<b>Power supply</b>	24 VAC (±5%), 15...35 VDC
<b>Consumption</b>	< 2,5 W
<b>Sensible element</b>	NDIR self adjusting
<b>Output</b>	0...5 VDC, 0...10 VDC, 4...20 mA, Modbus 485
<b>Electrical connection</b>	Pluggable screw terminal for cables 1,5 mm <sup>2</sup>
<b>Protection type</b>	IP41
<b>Working range RH</b>	10...95% RH in contaminant-free, non-condensing air
<b>Working temperature °C</b>	-30...+70°C
<b>Storage temperature</b>	-20...+50°C
<b>Standards</b>	CE conformity, RoHS



## Order matrix

Model	Output 1 CO <sub>2</sub>	Output 2 Temperature	Output 3 Humidity	Option
<b>KSIC</b>	<b>0</b> no output	<b>0</b> no output	<b>0</b> no output	<b>M</b> Modbus
	<b>1</b> 0...10 V	<b>1</b> 0...10 V	<b>1</b> 0...10 V	<b>D</b> Display
	<b>2</b> 2...10 V	<b>2</b> 2...10 V	<b>2</b> 2...10 V	<b>R</b> Relay*
	<b>3</b> 0...5 V	<b>3</b> 0...5 V	<b>3</b> 0...5 V	
	<b>4</b> 1...5 V	<b>4</b> 1...5 V	<b>4</b> 1...5 V	
	<b>5</b> 4...20 mA	<b>5</b> 4...20 mA	<b>5</b> 4...20 mA	

\* The relay option is available only with display.

## DIP Switch

DIP 1-2	CO2 Ranges	DIP 4	Response
	400-2.000 ppm		60 sec.
	0-2.000 ppm		20 sec.
	0-5.000 ppm		
	0-10.000 ppm		



## Transmitter hardware

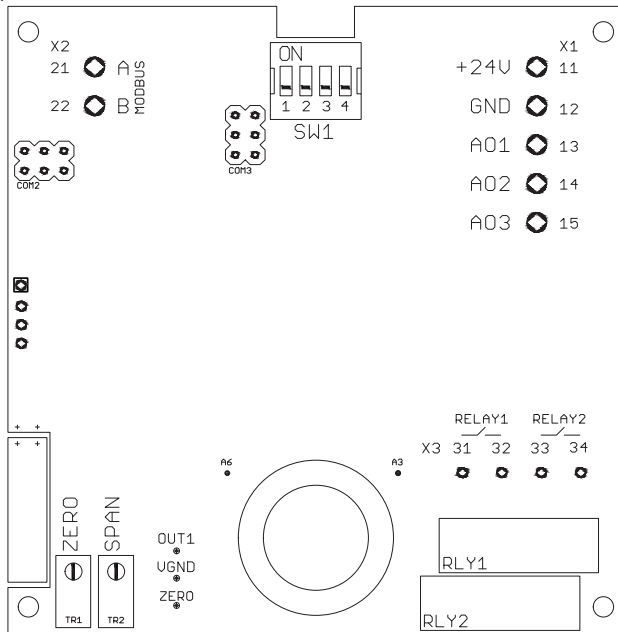

SW1 DIP Switch for configuration range and response time

### X1 TERMINAL

11	24V	15...35 VDC or 24 VAC ( $\pm$ %5, 50-60 Hz)
12	GND	ground for power and reference for outputs
13	AO1	analog output 1
14	AO2	analog output 2
15	AO3	analog output 3

### X2 TERMINAL

21	A / RS485	modbus communication positive pair
22	B / RS485	modbus communication negative pair

RLY1 & RLY2 relay 1 and relay 2

### X3 TERMINAL

31	NO - RL1	relay 1 dry contact max. rating 1A @ 230 VAC
32	NO - RL1	relay 1 dry contact max. rating 1A @ 230 VAC

## Electrical wirings

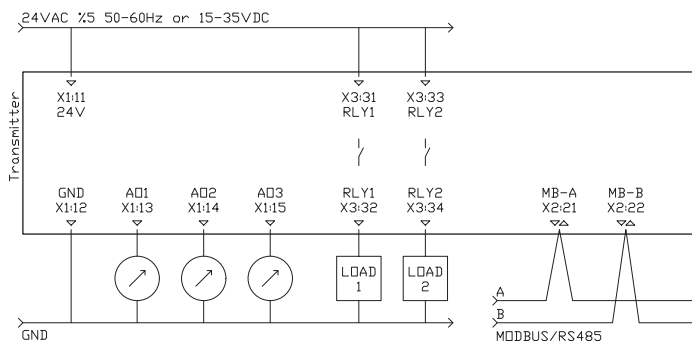

Relay contact rating is max. 1A at 230 VAC  
 We kindly advise using 24V for avoiding high voltage harmonics and external power relay for bigger loads  
 Please use shielded and twisted paired cables for Modbus connections



## Display & Buttons

keep pressing until entering MENU, click for next parameter

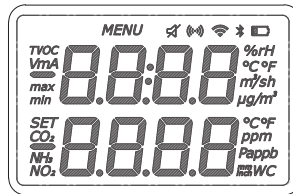

press for increasing the value or choosing the next parameter

press for EXIT



press for decreasing the value or choosing the previous parameter



main screen  
transmitter is working



keep pressing MENU button until seeing 0  
transmitter is not working in MENU mode

## Parameters for Relay & Buzzer

Main Screen >>>> r1 L > r1 H > r1 A > Main Screen

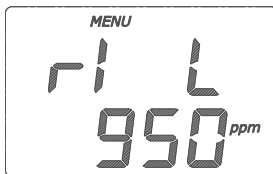

LOW set point for Relay 1

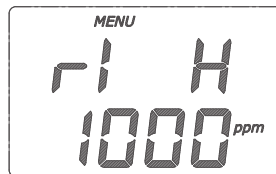

HIGH set point for Relay 1

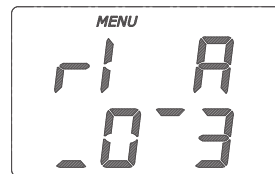

ACTION selection for Relay 1

## Actions for Relay & Buzzer



action 0,  
relay contact is always OPEN



action 1,  
relay contact is CLOSED between points, OPEN under LOWpoint and OPEN over HIGHpoint



action 2,  
relay contact is OPEN between points, CLOSED under LOWpoint and OPEN over HIGHpoint

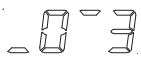

action 3,  
relay contact is CLOSED over HIGHpoint, OPEN under LOWpoint, hysteresis between points

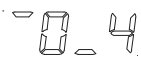

action 4,  
relay contact is OPEN over HIGHpoint, CLOSED under LOWpoint, hysteresis between points



ACTIONS	under LOW	between LOW & HIGH	over HIGH
0 : 0.0.0	Open	Open	Open
1 : 0.1.0	Open	Closed	Open
2 : 1.0.1	Closed	Open	Closed
3 : 0.X.1	Open	Hysteresis	Closed
4 : 1.X.0	Closed	Hysteresis	Open

0 : Relay Contact is OPEN, Buzzer is in Silent mode

1 : Relay Contact is CLOSED, Buzzer is in Warning mode

X : Relay Contact is at HYSTERESIS position, OPEN if previous position open, CLOSED if previous position closed

## Modbus RS485 protocol

Default Settings: Modbus ID:1, 9600, 8bit, None, 1. Register Table starts from Base 1.

Use Function 3 for Reading and Function 6 for Writing Holding Registers. Whenever writing to any Modbus Parameter, new parameter is activated instantly and you should have to configure master device according to new parameters. For every reboot/initializing, Modbus is activated with default parameters for 3 seconds. After 3 seconds, Modbus is reconfigured according your parameter settings.

Unlisted registers are for analog output calibrations and some system parameters. Please do not change unlisted registers.

Register	R/W	Range	Description
1	R & W	1...254	Modbus Address
2	R & W	0...4	Baudrate, 0: 9.600, 1: 19.200, 2: 38.400, 3: 57.600, 4: 115.200
3	R & W	0...3	Bit_Parity_Stop, 0: 8bit_None_1, 1: 8bit_None_2, 2: 8bit_Even_1, 3: 8bit_Odd_1
4	R		CO2 level as ppm
5	R		Temperature as C x100, divide by 100 for exact value
6	R	0 or 1	Relay 1, contact position, 0: OFF - Contact is Open, 1: ON - Contact is Closed
7	R	0...1.000	Relay 1, LOW point
8	R	0...1.000	Relay 1, HIGH point
9	R	0...4	Relay 1, ACTION
10	R	0 or 1	Relay 2, contact position, 0: OFF - Contact is Open, 1: ON - Contact is Closed
11	R	0...1.000	Relay 2, LOW point
12	R	0...1.000	Relay 2, HIGH point
13	R	0...4	Relay 2, ACTION
14	R	0 or 1	Buzzer, 0: OK-Silence, 1: PreAlarm - warning intermittently, 2: WARNING continuously
15	R	0...1.000	Buzzer, LOW point
16	R	0...1.000	Buzzer, HIGH point
17	R	0...4	Buzzer, ACTION
18-29	R		Only for service needs
30	R		CO2 level as ppm
31	R		Temperature as C x100, divide by 100 for exact value
32	R		Temperature as C
33	R		Temperature as F x100, divide by 100 for exact value
34	R		Temperature as F
35	R		Humidity as %rH x100, divide by 100 for exact value
36	R		Humidity as %rH



## ■ Dimensions (mm)

