



Description

The actuator series AVG10 has been designed to control the screwed globe valves series VG from DN50 up to DN80. The actuator is equipped by a bidirectional synchronous motor at 1000 N and available in ON-OFF, floating and proportional version. Fast and easy assembly. The actuator is fitted with manual override for the drive in case of power failure.

Technical specifications

Power supply	See schedule
Electrical connection	Screw terminal
Torque	1000 N
Max. stroke	20 mm
Running time	see schedule
Materials	ABS cover, self-extinguishing
Protection degree	IP54
Protection class	II
Working range °C	-10...+50°C
Storage temperature and humidity	-10...+50°C, 1...95% RH, non-condensing
Fluid temperature	< 150°C
Maintenance	Free



Models	Power supply	Action	Consumption	Running time
AVG10	24 V AC, 50/60 Hz ±10%	on-off, floating	5,8 VA	50 Hz, 160 sec. 60 Hz, 130 sec.
AVG10B	230 V AC, 50/60 Hz	on-off, floating	7,5 VA	
AVG10M	24 V AC, 50/60 Hz ±10%	proportional	5,8 VA	

Electrical wiring

AVG10M (proportional)

Terminal J1:

UP: When short-circuiting with 24 VAC COMMON, then the stem goes completely up (direct way close).
The position of W3 has no effect.

DOWN: When short-circuiting with 24 VAC COMMON, then the stem goes completely down (direct way open).
The position of W3 has no effect.

24 VAC POWER / 24 VAC COMMON: input terminal at 24 VAC. 24 VAC COMMON is connected with SIGNAL COMMON.

SIGNAL COMMON: Input signal 4...20 mA (2...10 V DC) / 0...20 mA (0...10 V DC). W2 and W4 must be set according to the input signal.

Feedback: Feedback signal. There is a signal 0...10 V DC or 2...10 V DC depending on the setting of W2.

AVG10 (on-off, floating)

- 5: Common
- 4: Stem down (direct way open)
- 3: Feedback with stem down (24 V AC Ver.)
- 2: Stem up (direct way close)
- 1: Feedback with stem up (24 V AC Ver.)

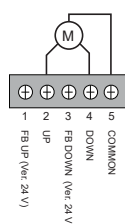

AVG10B (on-off, floating)

- 1: Common
- 2: Stem down (direct way open)
- 3: Stem up (direct way close)

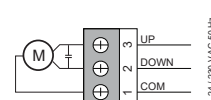

AVG10

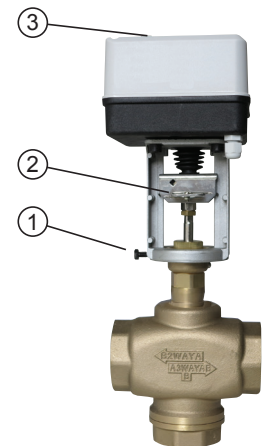

Installation

- Place motor on the valve and, having placed in seat, tighten the locking screw (1).
- Push the steel plate (2) and raise the valve stem or, alternatively, drive down the actuator shaft by manual override (3).
- Make the electrical connections as shown in the previous diagrams and (only for AVG10M) provide for the jumper settings.

Setting (AVG10M)

- W1:** 0%, 50%, 100%. Set the position of valve stroke in case of malfunction or failure of input signal.
 - 0% stem completely up 50% stem at halfway 100% stem completely down
 - Moving the jumper W3, the situation is reversed.
 - 0% stem completely down 50% stem at halfway 100% stem completely up
- W2:** 4...20 mA (2...10 V DC) / 0...20 mA (0...10 V DC). This jumper must be set according to W4 to select the input signal to J1.
- W3:** Reverse operation. Moving the jumper inverts the logic of operation as compared to the input signal.
- W4:** mA / V DC. This jumper must be set along with W2 to select the input signal to J1.

LED Status Indicator (work): Normal operating status: flashing slowly (1 sec on, one sec off). During the self-adaptation of the actuator on the valve (after pressing S1 for at least 3 sec) flashes rapidly (0.25 sec on, 0.25 sec off).

Self-adjustment in an error state: blinks twice quickly and off for a long time (on 0.25 sec, off for 0.25 sec, twice, then off by 1.25 sec).

LED indication of the rotation direction of the motor:

When the LED **D50** lights up, the valve rod moves downward. When the valve rod reaches the bottom and hold the position for 25 seconds, the LED turns off.

When the LED **D60** lights up, the valve rod moves upward. When the valve rod reaches the top and hold the position for 25 seconds, the LED turns off.

Self-adjustment of the actuator to the valve. Each actuator must be adapted to the valve to which it is coupled. Do not start adaptation at the bottom of the valve stem.

Press and hold the "**S1**" key for 3 sec, the actuator automatically will enter the self-adjustment. The LED "work" is flashing rapidly (on 0.25 sec., off 0.25 sec.). The valve shaft moves down to the bottom, and then maintains the position for 25 sec and then move upward until the upper point. The self-adjustment does not end until the valve shaft does not hold the final position for 25 sec.

To self-adaptation occurred (the previous data is overwritten), the actuator returns to normal operation. Otherwise (the previous data is not overwritten), will be reported the failure of the state of self-adjustment (on 0.25 sec., off 0.25 sec., twice, then off by 1.25 sec.). You can hold down the "S1" key for 3 sec to retry the process of self-adjustment, or reboot (power cycle) of the actuator to return to normal working state.

Possible problems of self-adjustment:

- 1: It occurs in the case where the stroke is reached less than half the nominal stroke.
- 2: The connection of the potentiometer is wrong (terminal J2). Correct way: when the valve shaft is downward the potentiometer has the maximum value, when the valve shaft is upward the potentiometer has the minimum value.

Printed circuit board (AVG10M)

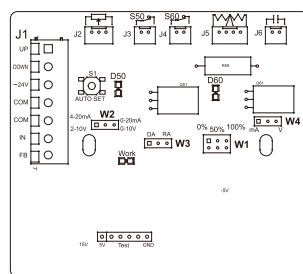

Dimensions (mm)

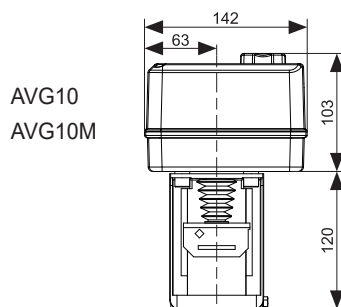

AVG10B

