

**Actuator for flanged globe valve
DN250, DN300**

AVFF65, AVFF100



Description

Linear electric actuator AVFF65/100 series for HVAC applications. Supports 0–10 V / 4–20 mA control signals, high accuracy (up to 0.4%), stroke up to 100 mm and thrust up to 10 kN. Compact and reliable, featuring auto-calibration, manual operation, and complete overload protection.

Technical specifications

| | |
|---|--|
| Power supply | 230 V AC ±10% 50/60 Hz |
| Power consumption | ≤ 35 VA |
| Electrical connection | Screw terminal, 1,5 mm ² |
| Torque | 6500 N, 10000 N |
| Running time | 2,1 sec./mm (50Hz) |
| Materials | ABS cover, self-extinguishing Aluminium bracket |
| Protection degree | IP65 |
| Life time | at least 80.000 cycles |
| Working range °C | -5...+55°C |
| Storage temperature and humidity | -25...+55°C, 1...95% RH, non-condensing |
| Maintenance | free |



| Models | Force kN | Action | Input signal | Stroke mm | Speed | DN mm |
|-----------|----------|------------------|-------------------------------|-----------|----------|-------|
| AVFF65B | 6,5 | on-off, floating | 3-points | 60 | 2,1 mm/s | 250 |
| AVFF65BM | | proportional | 0(2)...10 V DC - 0(4)...20 mA | | | |
| AVFF100B | 10 | on-off, floating | 3-points | 100 | | 300 |
| AVFF100BM | | proportional | 0(2)...10 V DC - 0(4)...20 mA | | | |

Electrical wiring

On-off, floating

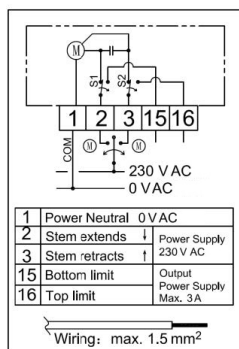

Proportional

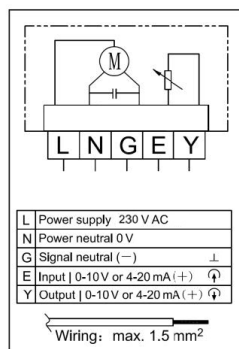

On-off, floating

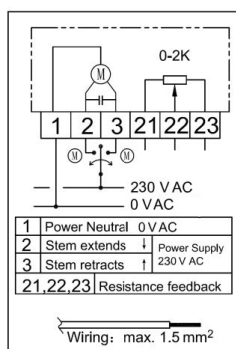

Proportional with two auxiliary switches

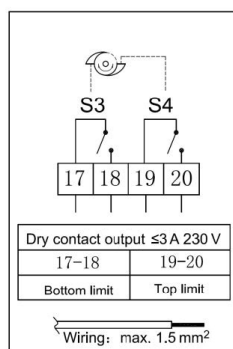



Mounting instructions

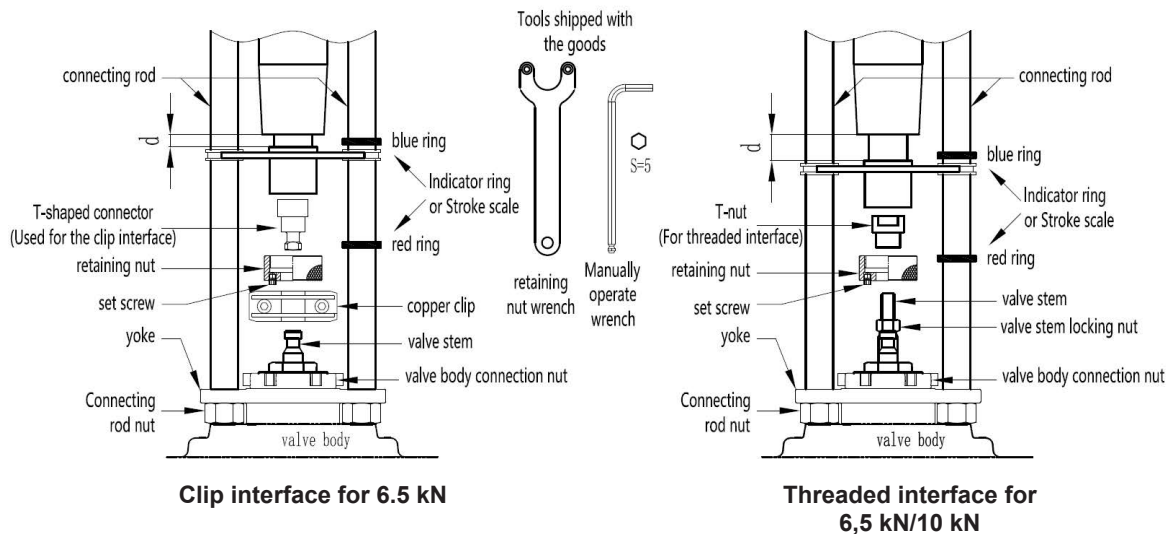

As shown in the figure above, install the electric actuator of the corresponding model onto the required regulating valve body: the connection dimensions between the valve and the actuator

Assembly steps for Clip interface:

- 1) Remove a pair of "copper clips" and "valve body connection nuts" from the actuator and set them aside for future use.
- 2) Before installation, the valve stem of the valve should be at the top position; Place the actuator on the valve and use the output stem of the actuator to push the valve stem to an appropriate position, ensuring that the end faces of the two stems coincide.
- 3) Insert the "valve body connection nut" between the top of the valve stem and the actuator rod, slip it onto the neck of the valve, screw it to the root to fix the actuator, but do not tighten it.
- 4) When the end faces of the actuator shaft and the valve stem do not coincide, use the "manual operation wrench" to make the output shaft of the actuator run downward until they coincide, and then stop.
- 5) Use the "copper clip", buckle them together, clamp the valve stem and the actuator shaft and connect them together, and fix them firmly with the matching screws and nuts; (Pay attention to the installation direction of the clip. If it is installed backwards, it cannot be used!)
- 6) Power on the actuator or operate it manually, move the mechanism upward to the top limit position, allow the mechanism to automatically align under tension and maintain a coaxial state, and then tighten the "valve body connection nut".
- 7) Itinerary Instructions:
 - Indicator ring: Slide the indicator ring so that it is close to the pointer.
 - Stroke scale: Paste the stroke scale indicator on the outer surface of the clean and legible "connecting rod".

Assembly steps for threaded interface:

- 1) Remove the "valve body connection nut", "retaining nut" on the actuator and the "T-nut" inside.
- 2) Push the valve stem to the bottommost position, and screw the "valve stem locking nut" to the lowermost end of the connecting thread of the "valve stem".
- 3) Put the unscrewed "retaining nut" onto the valve stem and place it loosely on the "valve stem jam nut".
- 4) Crew the "T-nut" into the valve stem in the direction shown in the above figure. When the upper surface of the "valve stem" is 0-5mm lower than the upper surface of the nut, tighten the "valve stem locknut" in the reverse direction to fix the "T-nut".
- 5) Manually operate the actuator to make the lower end face of the output shaft of the actuator move away from the upper end face of the valve stem or run to the uppermost position.
- 6) Insert the "valve body connecting nut" between the top of the valve stem and the actuator rod, put the actuator onto the valve body, slide the "valve body connecting nut" to the valve neck, and screw it to the root to fix the actuator, but do not tighten it.
- 7) Power on or manually operate the actuator to run downward. After the output shaft contacts the "retaining nut", tighten the "retaining nut" onto the output shaft, and finally tighten the "set screw" to prevent loosening.
- 8) Power on the actuator or operate it manually, move the mechanism upward to the top limit position, allow the mechanism to automatically align under tension and maintain a coaxial state, and then tighten the "valve body connection nut".
- 9) Itinerary Instructions:
 - Indicator ring: Slide the indicator ring so that it is close to the pointer.
 - Stroke scale: Paste the stroke scale indicator on the outer surface of the clean and legible "connecting rod".
- 10) The mechanical connection is completed. The 3-Point control signal can be used directly. For the analog control signal, it needs to be powered on and go through the Stroke self-calibration before use.

Note: When the actuator descends to the lower dead center of the valve, the exposed length d of the output shaft nut (as shown in the figure) should be \leq the rated stroke of the actuator (60mm or 100mm) to prevent the output shaft of the actuator from disengaging from the mechanism.

AVFF65, AVFF100



Mounting instructions

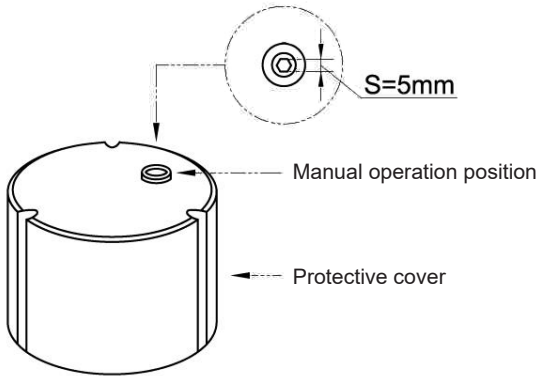

Manual operation function is used to debug the equipment during on - site installation or in case of an emergency when an electrical failure occurs.

The steps are as follows:

1. Cut off the power supply of the actuator at the handwheel shaft.
2. Connect (with a size of 5mm) to the handwheel shaft through the manual operation installation hole on the cap.
3. According to the on - site usage situation, rotate the wrench clockwise or counter - clockwise. The rotation speed should be $\geq 6s/r$ (to prevent the equipment mechanism from being damaged due to excessive rotation speed).
 - When rotating clockwise, the output shaft of the actuator moves upward.
 - When rotating counter - clockwise, the output shaft of the actuator moves downward.
4. After the valve reaches the designated position, stop rotating and take out the wrench.

Note: 1. During manual operation, it is strictly prohibited for the pointer to exceed the range of the upper and lower indicator rings.
2. When the output shaft is working within the range of the indicator ring, if significant resistance is encountered, determine the cause before further operation.

Technology

3 position control signal

Terminals 1 - 2 are powered on: The actuator stem extends.

Terminals 1 - 3 are powered on: The actuator stem retracts.

No voltage on 2 and 3 the actuator stem remain in the respective position.

Note: It is strictly prohibited to power on terminals 1 - 2 and 1 - 3 simultaneously. Otherwise, the equipment will be damaged!

Instructions for the actuator panel with an electronic locator

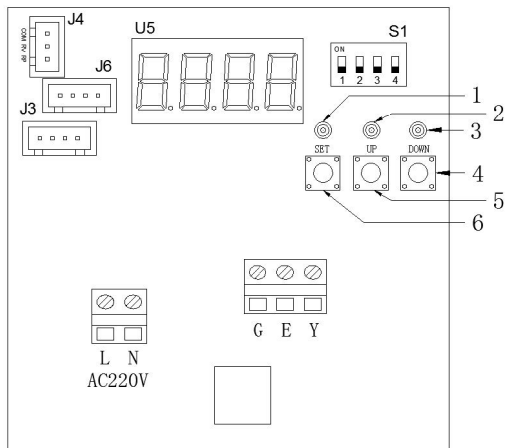

- U5: display
- 1: SET Indicator light
- 2: UP Indicator light
- 3: DOWN Indicator light
- 4: DOWN button
- 5: UP button
- 6: SET button
- S1: Signal type selector
- J3: Motor socket
- J4: Power socket
- J6: Limit switch socket

Status and setting of 4-digit DIP switch S1

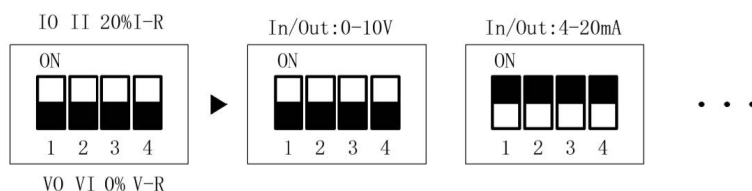

DIP1: Feedback signal type: ON= current output, OFF= voltage output

DIP2: input current input, OFF= voltage input

DIP3: Starting point selector, i.e., percentage of the starting point and full point of input and output signals.

OFF: 0%; e.g., DC0-10V, DC0-20mA etc. ON: 20%; e.g., DC2-10V, DC4-20mA etc.

DIP4: Resistance matching for input signals (The same as the DIP2)

ON-Perform resistance matching for the current input signal OFF- Perform resistance matching for the voltage input signal



| S1-DIP | Signal type selector | | | | | | | |
|--------|----------------------|----------------|-------------------|---------------|-------------------------|-----|---------------------------------------|------------|
| | Output signal type | | Input signal type | | Starting point selector | | Resistance matching for input signals | |
| | voltage output | current output | voltage Input | current input | 0% | 20% | at voltage | at current |
| DIP1 | OFF | ON | | | | | | |
| DIP2 | | | OFF | ON | | | | |
| DIP3 | | | | | OFF | ON | | |
| DIP4 | | | | | | | OFF | ON |

Function Description

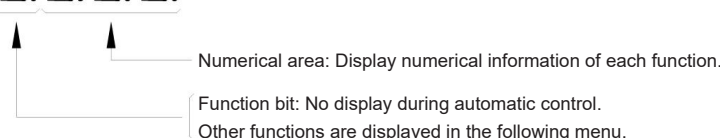

1. Quick debugging (Auto-calibration of valve stroke):

After each power - on of the device, it directly enters the “automatic control” state. In the “automatic control” state, press and hold the [“SET”] key for three seconds, then the auto-calibration program will be started:

- The actuator rod moves downward first. The “SET indicator light” and “UP indicator light” flash, and the “DOWN indicator light” is always on.
- Stop slightly at the bottom dead center, memorize it and then move upward. The “SET indicator light” and “DOWN indicator light” flash, and the “UP indicator light” remains on. Move upward to the limit position, stop slightly, memorize it, and then all indicator lights stop flashing. The auto-calibration is completed.

2. Manual/Auto control status

In the normal “automatic control” state, when the [“SET” + “UP”] two keys are pressed simultaneously for three seconds, the “automatic control” and “manual control” states can be switched alternately. In the “manual control” state, the function bit displays “H”, and at this time, the up and down actions of the actuator can be operated through the [“UP”] key or the [“DOWN”] key.

3. Automatic control state

3.1 Feedback signal display

Under the normal “automatic control” state, there is no display of the function bit. At this time, the value displayed in the numerical area of the display screen is the percentage value of the valve position feedback signal.

3.2 Input Signal Display

In the normal “automatic control” state, by switching the [“DOWN”] key, the percentage value of the valve position feedback signal and the percentage value of the input signal can be alternately displayed in the numerical area of the display screen. When the percentage value of the input signal is displayed in the numerical area, the function position shows “. After the percentage value of the input signal is displayed for 10 seconds without any operation, it will automatically return to the normal “automatic control” state.

4. Overload alarm function:

For the actuator, stalling (when the resistance value of the potentiometer does not change within 30 seconds) at non - extreme positions (near the two dead - point positions, that is, within 5% of approaching zero and full scale) is regarded as a fault. At this time, the current feedback value and E01 are displayed alternately, and the output of the thyristor is cut off. Then, try to output again after 30 seconds, and repeat this process.



■ Engineers set parameters

In the "Automatic Control" state, press and hold the three keys ["SET" + "UP" + "DOWN"] simultaneously for three seconds to enter the engineer parameter setting state. Press the ["SET"] key in sequence, and the function bit and the value area will flash alternately. When the function bit is flashing and the value area is not flashing, you can change the function bit through the ["UP"] and ["DOWN"] keys. When the value area is flashing and the function area is not flashing, you can change the value in the value area through the ["UP"] and ["DOWN"] keys. In the parameter setting state, if there is no operation for more than 10 seconds, it will return to the "Automatic Control" state.

Conventional "Function Bit" Display Table

| Function description | Function bit | Display | Explanation |
|---------------------------------|--------------|---------|--|
| Position feedback | No display | | Numeric range: 0% - 100% In automatic mode, only the position feedback value is displayed. In the automatic state, if you need to view the input signal values, you can use the DOWN key to switch between the position feedback values and the input signal values. |
| Input signal | | | Note: After 10 seconds of no operation while the input signal value is displayed, the positioner automatically reverts to the state of displaying the position feedback value. |
| Manual function | | | Numeric range: 0% - 100% Only display the position feedback value. It is not allowed to switch to the input signal display state. In this state, the actuator can be operated to run by pressing the „UP“ key or the „DOWN“ key. Phenomenon: Flashing the current feedback value |
| Stroke calibration alarm | | | E00 = Warning that the stroke calibration has not been completed correctly. Phenomenon: The UP and DOWN indicator lights flash alternately with an interval of 1 second. |
| Locked Rotor Alarm | | | E01 = Locked Rotor Alarm (The overload switch has been triggered) 1. Upward rotation blocking alarm Phenomenon-The alarm code E01 flashes, and the SET and UP indicator lights flash together with a cycle of 1 second. 2. Downward blocking alarm Phenomenon-The alarm code E01 flashes, and the SET and DOWN indicator lights flash together with a cycle of 1 second. |
| Lost signal alarm | | | E02= Lost signal alarm In the automatic state, if the input signal line is disconnected, the positioner determines it as a lost signal alarm. |
| Potentiometer Upper Limit Alarm | | | E03= Potentiometer upper limit alarm In the automatic state, when the output shaft of the mechanism moves upward to the potentiometer protection position, the positioner determines it as an upper limit alarm. |
| Potentiometer Lower Limit Alarm | | | E04= Potentiometer lower limit alarm In the automatic state, when the output shaft of the mechanism descends to the potentiometer protection position, the positioner judges it as a lower limit alarm. |
| Operating failure | | | E05 = Actuator running failure, such as abnormal transmission system, or abnormal potentiometer operation, etc. 1. Downward failure Phenomenon: Display E05, and the DOWN indicator light flashes 3 times and pauses for 1s. 2. Upward failure Phenomenon: Display E05, and the UP indicator light flashes 3 times and pauses for 1s. |

AVFF65, AVFF100



| Level 1 parameter table | | | |
|--|--------------|---|--|
| Function description | Function bit | Display | Factory values |
| Starting point selector | 1 | 1 00 1 01 | Selection of the starting point of the input signal. Value range: 00 = 0%, 01 = 20% Note: The DIP switch settings take precedence. This parameter does not need to be set and can use the default value. |
| Direct or inverse acting selector | 2 | 2 00 2 01 | Value range: 00, 01 00= Direct acting (Signal increases, the output shaft of the actuator moves upward) 01= Inverse acting (Signal increases, the output shaft of the actuator moves downward) Note: When not specified, the factory default is "00". |
| The working mode of the lost signal | 3 | 3 00 3 01 3 02 | Value range: 00, 01, 02 00= Downward movement 01= Upward movement 02= Hold the position, Note: The default setting at the factory is "00". |
| Lower limit value of the stroke Kv-min | 4 | Value range: 0-55 | Stroke limit setting when the input signal is at 0% 00= Disable The factory default is "00". |
| Upper limit value of the stroke Kv-max | 5 | Value range: 55-100 | Stroke limit setting when the input signal is at 100% 100= Disable; The factory default is "100". |
| Flow characteristic | 6 | Value range: 00, 01, 02 | The curve relationship between the percentage of the input signal and the percentage of the stroke: 00= Linear, 01= Equal percentage, 02= Reverse equal percentage The factory default is "00". |
| Rangeability | 7 | Value range: 25, 30, 33, 50, 60, 80, 100 | Only available when the equal percentage characteristic is used. Note: The factory default is "30". |
| Level 2 parameters unlocking bit | 8 | | Users cannot change it at will. Note: The default factory setting is "08". Set it to "16", and after confirmation, enter the level 2 parameters setting. |

| Level 2 parameter table | | | |
|--------------------------|--------------|---------------|--|
| Function description | Function bit | Display | Factory values |
| Signal dead zone setting | 9 | 9 05 9 100 | Value range: 0.4-10.0 !! Please change with caution. Note: The default factory setting is "0.6", and the dead zone parameter is 0.6%. If it is set to "2.0", after confirmation, the dead zone parameter will be 2.0%. |

AVFF65, AVFF100



Installation and Precautions

10.1 Installation requirements

- Easy to access.
- Leave space to remove the protective cover.
- The actuator shall not be installed upside down.
- Pay attention to the operating ambient temperature.
- For actuators installed outdoors, a protective cover must be installed, and attention should be paid to ventilation and heat dissipation. Please note that the interior of this actuator should not be wetted or frosted.
- Before connecting the power supply, please make sure that the power supply voltage is consistent with the voltage marked on the nameplate of this actuator.
- This actuator is not allowed to operate naked to prevent mechanical entanglement or electric shock hazards.

10.2 Transportation and Storage

- Appropriate packaging must be carried out according to the transportation conditions for delivery to the installation site.
- It is prohibited to place any device on the actuator.
- Store in a dry and well - ventilated place and prevent it from getting damp.
- Cover it to prevent dust.
- Apply anti - corrosion paint to the bright metal surface.

10.3 Maintenance and Upkeep

Note: Cut off the power supply of the equipment before any maintenance work.

Under normal use conditions, non-professionals should not easily open the protective cover of the actuator. The actuator itself can operate normally for several years.

During maintenance: If it is necessary to force open or close the electric valve, the actuator can be operated through the handwheel mechanism. If there is no handwheel configured, the actuator can be operated by means of powered operation.

After startup: Check if there is any paint damage on the entire machine. If necessary, repaint it to prevent corrosion.

For rare startups: Check the performance of the actuator every six months after startup.

One year later: Check whether the mechanical connection with the valve body is reliable. If necessary, tighten it again. Check whether the lubrication of the gears and transmission parts is dry. If needed, add an appropriate amount of high-quality solid lubricating grease.

A few years later: Depending on the operating condition of the equipment after a few years, if major repairs or adjustments are required, please consult us for a comprehensive maintenance plan.

Dimensions (mm)

