



Description

The SDCM CO₂ sensor measures air quality through the presence of carbon dioxide in air ducts in the range between 0 and 2000 ppm. The measurement of CO₂ concentration happens through a NDIR sensor that operates on an infrared basis and which compensates the presence of any impurity. The product is provided with ModBus 485 output.

Technical specifications

Measurement range CO₂	0...2000 ppm
Accuracy CO₂	< ± 60 ppm +2% FS (at 25°C and 1013 mbar)
Accuracy temperature (*)	±0,3°C (5...60°C) + 1% FS
Accuracy humidity (*)	±2% RH (20...80%RH) + 2% FS
Power supply	12...24 V AC/DC
Consumption	max. 9 mA
Sensible element	NDIR self adjusting
Output	ModBus RS485 (ASCII/RTU)
Electrical connection	Screw terminal for cables 1,5 mm ²
Protection type	IP65
Working range RH	10...95% RH in contaminant-free, non-condensing air
Working temperature °C	-20...+50°C
Storage temperature	-20...+50°C
Installation	Mounting flange (included)
Standards	CE conformity, RoHS



Model	Temperature	Humidity
SDCM	-	-
SDCTM	•	-
SDCTHM	•	•

Measurement source

Unit	ModBus source	Gain
ppm CO ₂	10	10
Temperature °C	20	10
Relative humidity %u.r.	21	10
Absolute humidity g/m ³	22	10
Dewpoint °C	23	10
Enthalpy J	24	10

Electrical wirings

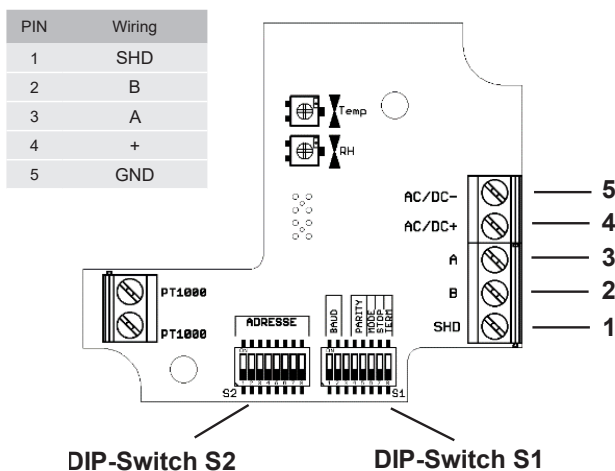

DIP Switch 1	Setting	1	2	3	4	5	6	7	8
	Baudrate								
	9600	OFF	OFF						
	19200	OFF	ON						
	38400	ON	OFF						
	57600	ON	ON						
Termination									
	nessuna								OFF
	120 Ω								ON
Parity									
	Even				OFF	OFF			
	Odd				OFF	ON			
	No parità				ON	OFF			
	No parità				ON	ON			
Modality									
	RTU							OFF	
	ASCII							ON	
Bit stop									
	1								OFF
	2								ON

