



Description

The RTA50 series controllers are microprocessor-based devices designed to control heating / cooling systems with 2 or 4-pipe fan coils or chilled beam systems. They are also suitable for fan coils control with electric resistance or systems that combine fan coils with floor heating systems.

Technical specifications

- Application: fan coils 2 pipes, 4 pipes, 2 pipes with s/w electrical resistance sequence, 2 pipes with floor heating sequence, chilled beams with dew point limit.
- Digital regulator with proportional + integral action
- Fan speed control with 0 ... 10 V DC or three-speed output
- Control action for actuators: ON-OFF, PWM, three-point floating, 0 ... 10 V DC
- Output control voltage: actuators for 230 or 24 Vac valves, 0...10 V DC or 230 V AC fan
- Power supply voltage: 230 V AC, 50/60 Hz
- LCD display
- Version with remote room module
- Version with Real Time Clock
- Local Master-Slave control for up to 4 slave controllers
- Mounting on 503 box
- CE certification
- Communication output with Modbus RTU protocol

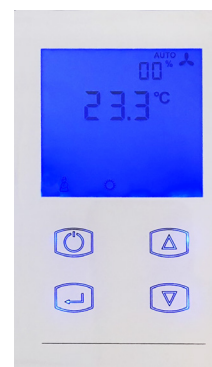

Models	Display	Mounting	Color	Control action	Supply
RTA50HW	●	Horizontal to 3-module flush-mounting box	White	ON-OFF / PWM	230 V AC
RTA50HG	●	Horizontal to 3-module flush-mounting box	Grey	ON-OFF / PWM	230 V AC
RTA50VW	●	Vertical to 3-module flush-mounting box	White	ON-OFF / PWM	230 V AC
RTA50VG	●	Vertical to 3-module flush-mounting box	Grey	ON-OFF / PWM	230 V AC
RTA51A	-	DIN rail	-	ON-OFF / PWM / Floating	24 V AC
RTA51B	-	DIN rail	-	ON-OFF / PWM / Floating	230 V AC
RTA51HG	Remote display	Horizontal to 3-module flush-mounting box	Grey	-	-
RTA51VG	Remote display	Vertical to 3-module flush-mounting box	Grey	-	-
RTA51HW	Remote display	Horizontal to 3-module flush-mounting box	White	-	-
RTA51VW	Remote display	Vertical to 3-module flush-mounting box	White	-	-

Input and Output

Digital inputs

Presence contact or time program: (RTA50: terminals M14-M15, RTA51: terminal M19)

The contact open indicates the presence in the room (occupied room) and activates the set point on Comfort mode.

Window: (RTA50: terminals M13-M15; RTA51 terminal M18)

The contact open indicates the closed window and normal operation. The closing of the contact indicates the opening of the window and the changeover to antifrost operation. This causes valves closure and fan stop. The frost protection activates an ambient set point of 4°C.

Summer / Winter switching alternatively temperature remote sensor: (RTA50: terminals M22-M23; RTA51: terminal M21)

The contact close indicates the presence of hot water in the piping. This causes switching to winter operation. Summer/winter switching can also be carried out by using a temperature sensor connected to the same terminals.

Analog inputs

Air temperature sensor: (RTA50: terminals M21-M23; RTA51: terminal M22)

This NTC sensor normally positioned on the fan coil's return air and has priority over the controller's internal sensor.

Water temperature sensor: (RTA50: terminals M22-M23; RTA51 terminal M21)

If the sensor is present then activate by parameter P23 setting to default on „Without sensor“.



Analog and Digital outputs

Fan:
Fan speed regulation: proportional output 0 ... 10 V DC, 1 mA (RTA50: terminals M11 and M12; RTA51: terminals M23 and M24).
Additional outputs for 3-speed fans, 230 V AC 50 Hz, max 1.25 A (3 A peak) (RTA50: terminals M3, M4, M5 and M6; RTA51: M4, M5, M6).

Actuator heating valve:

ON-OFF or PWM output at 230 V AC 0.8 A suitable for controlling up to 4 thermal actuators (RTA50: terminals M9 and M8; RTA51: M8).
Output for floting actuators at 230 V, 0,8 A or 24 V AC (M8 open, M9 close)

Actuator cooling valve:

ON-OFF or PWM output at 230 V AC 0.8 A suitable for controlling up to 4 thermal actuators (RTA50: terminals M7 and M8; RTA51 M11).
Output for floting actuators at 230 V, 0,8 A or 24 V AC (M12 open, M11 close)

Auxiliary output:

230 V AC 0.8 A (RTA50: terminals M10 and M8; RTA51: M7).

Technical features

Control range			Terminals	
10...30° C			RTA50	RTA51
Power supply			230 V AC, 50/60 Hz	
Analog inputs				
Room temperature 0...40°C	Return air sensor (remote)	NTC10K	M21, M22	M22
Water temperature 0...80°C	Strap-on/screw-in sensor	NTC10K	M22, M23	M21
Sensor relative humidity	10...90 % rh	Internal sensor		
CO ² sensor	0...2000 ppm	Internal sensor		
Digital inputs				
	Summer winter changeover	Open contact = winter	M22, M23	M21
	Windows open or ON-OFF	Open contact = window closed = ON	M14, M15	M19
	Economy reduction	Close contact = Economy	M13, M15	M18
Digital outputs				
	Actuatpr heating valve	Min. 5 mA, Max 0,8A	M8, M9	M8 open, M9 close
	Actuator cooling valve	Min. 5 mA, Max 0,8A	M7, M8	M12 open, M11 close
	Auxiliary output	Min. 5 mA, Max 0,8A	M10, M8	M7
	Fan 3 speed	Min. 5 mA, Max 1,25A ^(*)	M2, M4, M5, M6	M4, M5, M6
Analog output			SELV 0...10 V DC	
			Max 10 mA	
			M11, M12	
			M23, M24	
Housing			Polycarbonate and ABS RAL9010	
Protection class			IP30	
Working temperature			0...45° C	
Storage temperature			-10...+70° C	
Working humidity			10...90% rh, non condensing	
Installation			On 3-module flush-mounting box	

(*) Connection for one fan only. For more fans use one relay for each speed.

Applications

1) 2-pipe fan coil system

Selectable s/w change-over by button on thermostat (manual), digital input by local or centralized contact, water temperature sensor.
Digital input for economy reduction and for window or power-off contact.
Input for optional remote room sensor.
Command for ON-OFF actuator.
3-speed fan motor or EC motor 0 ... 10 V DC.
Auxiliary output for electrical resistance in sequence to the heat valve.

2) 4-pipe fan coil system

Automatic season change over according to the room temperature.
Digital input for economy reduction and for window or power-off contact.
Input for optional remote room sensor.
Command for ON-OFF actuator.
3-speed fan motor or EC motor 0 ... 10 V DC.
Auxiliary output for electrical resistance in sequence to the heat valve.



3) Floor heating system and 2-pipe fan coil in sequence.

Selectable s/w change-over by button on thermostat (manual), digital input by local or centralized contact, water temperature sensor.
 Digital input for economy reduction and for window or power-off contact.
 Input for optional remote room sensor.
 Command for ON-OFF actuator.
 3-speed fan motor or EC motor 0 ... 10 V DC.
 Auxiliary output for electrical resistance in sequence to the heat valve.

4) 2-pipe fancoil system only cooling and battery with electrical resistance

Automatic season change over according to the room temperature.
 Digital input for economy reduction and for window or power-off contact.
 Input for optional remote room sensor.
 Command for ON-OFF actuator.
 3-speed fan motor or EC motor 0 ... 10 V DC.
 Command for electrical resistance with PWM regulation.

5) 2-pipe fancoil system and battery with electrical resistance

The electric battery is in sequence with the heating valve in winter while in summer it acts as a heat sequence with a cooling valve.
 Automatic season change over according to the room temperature.
 Digital input for economy reduction and for window or power-off contact.
 Input for optional remote room sensor.
 Command for ON-OFF actuator.
 Command for electrical resistance with PWM regulation.
 3-speed fan motor or EC motor 0 ... 10 V DC.

Parameter table

Parameter	Parameter description	Default value	Minimum value	Maximum value
1	Heating set point	20 °C	10 °C	30 °C
2	Cooling set point	25 °C	10 °C	30 °C
3	Set point limit	10 K	0 K	10 K
4	Proportional band	2 K	0 K	5 K
5	Economy reduction	2 K	0 K	10 K
6	Stand-by reduction	6 K	0 K	10 K
7	Anti-freeze temperature	4 °C	0 °C	10 °C
8	Offset reading of room temperature	0 K	-5 K	+5 K
9	Offset reading of room temperature (Remote sensor 1)	0 K	-5 K	+5 K
10	Offset reading of water temperature (Sensor 2)	0 K	-5 K	+5 K
11	Offset reading sensor 3	0 K	-5 K	+5 K
12	Display visualization mode 0 = room temperature display 1 = Set point display	0	0	1
13	Type of system 0 = 2 pipe 1 = 4 pipe 2 = Floor heating/cooling + 2 pipe heating/cooling fan-coil 3 = 2 pipes cooling + electrical resistance 4 = 2 pipes heating/cooling + electrical resistance S/W	0	0	4
14	Fan 0 = Thermostatic S/W 1 = Continuous S/W 2 = Continuous in cooling, thermostatic in heating 3 = Continuous in heating, thermostatic in cooling	0	0	3
15	EC fan motor with ON-OFF activation Delay EC fan start	0 sec	0 sec	240 sec
16	Type of output for actuators 0 = ON-OFF 1 = PWM 2 = Flotting / 3 point (only for RTA51)	0	0	1
17	Excursion time of floating actuators	240 sec	0 sec	300 sec

RTA50



Parameter	Parameter description	Default value	Minimum value	Maximum value
18	Digital input 1 0 = active = closed contact 1 = active = open contact 2 = open contact = alarm 3 = open contact = alarm	0	0	3
19	Digital input 2 0 = active = closed contact 1 = active = open contact	0	0	1
20	Analog input 1 0 = NTC10K sensor 1 = 4...20 mA (not available) 2 = 0...10 Vcd (not available)	0	0	2
21	Analog input 2 0 = NTC10K sensor 1 = 4...20 mA (not available) 2 = 0...10 Vdc (not available)	0	0	2
22	Display position 0 = Local 1 = Remote	0 (RTA50) 1 (RTA51)	0	1
23	Water temperature sensor function 0 = S/W changeover and fan consent 1 = S/W changeover 2 = Fan consent 3 = No sensor	3	0	3
24	S/W changeover mode 0 = Manual by display 1 = Strap-on or water sensor 2 = Automatic from room temperature sensor	0	0	2
25	Power-off delay fan with primary electric resistance	60 sec	0 sec	240 sec
26	Fan consent temperature in winter	35 °C	26 °C	50 °C
27	Fan consent temperature in summer	16 °C	10 °C	25 °C
28	Fan start delay in heating	60 sec	0 sec	240 sec
29	Time interval for destratification cycle	15 min	1 min	60 min
30	Destratification time	0 sec	0 sec	120 sec
31	Temperature difference value for auxiliary output insertion	0,5 K	0 K	10 K
32	Anti-sill time of the auxiliary exit	60 sec	1 sec	60 sec
33	Hours of functioning for dirty filter alarm (x 100)	0	0	100
34	Cyclic output insertion (for functional testing) 0 = excluded 1 = inserted	0	0	1
35	Minimum fan speed value (speed 1)	2 V	0 V	5 V
36	Speed value 2 fan	5 V	0 V	8 V
37	Fan speed maximum value (speed 3)	10 V	0 V	10 V
38	Fan speed with primary electric resistance	5 V	0 V	10 V
39	Set point priority setting 0 = local 1 = remote	0	0	1
40	Fan Speed Setting Priority 0 = local 1 = remote	0	0	1
41	Priority setting button 0 = local 1 = remote	0	0	1
42	Season priority setting 0 = local 1 = remote	0	0	1

RTA50



Parameter	Parameter description	Default value	Minimum value	Maximum value
43	Modbus speed setting 0 = 9600 Baud 1 = 14400 Baud 2 = 19200 Baud 3 = 38400 Baud	0	0	3
44	Modbus parity setting 0 = No parity 1 = ODD 2 = EVEN	0	0	2
45	Modbus Stop Bit Setting 0 = 1 Bit of Stop 1 = 2 Bit of Stop	0	0	1
46	ModBus address setting	0	0	255
47	Fan speed setting It is set if P39 is set at 1 Settable value: 1=AUTO 2=FAN OFF 3=FAN VEL. 1 4=FAN VEL. 2 5=FAN VEL. 3 Free settable value:	0 0,1 V	0 0,1 V	5 10 V
48	Integral time	60 sec	0 sec	255 sec

Installation

The RTA50 controller is installed on the wall into a 503 box.

It is equipped with plug-in terminals, which allow a quick and practical connection to the electrical devices on the fan coil. Alternatively, the remote room module can be installed with a 2-wire connection to the controller.

Modbus communication

The controller is provided with an output for communication with the Modbus RTU protocol.

The connection to the Modbus bus is made with 2 wires connected to the terminals located on the lower left side of the controller. See in the figure: CONN1. (A + B)

Follow the instructions given in the Modbus standards regarding cable type, length and especially the position of the cables with respect to line voltage cables.

Take care not to assign the same address to more than one controller on the same bus.



Electrical wiring

Terminal	Connection
1	phase power supply
2	neutral power supply
3	neutral for fan outputs
4	fan-speed 1
5	fan-speed 2
6	fan-speed 3
7	output for cold actuator / valve
8	common neutral actuators
9	output for hot actuator / valve
10	auxiliary output
11	0 ... 10 V DC output for fan (+)
12	0 ... 10 V DC output for fan (-)
13	eco digital input, setpoint reduction
14	window digital input / shutdown
15	common digital inputs
16	local bus for slave controllers
17	MODBUS output (-)
18	MODBUS exit (+)
19	+ 12 V DC power supply
20	4 ... 20 mA input
21	analogue input for remote room sensor
22	analogue input water temperature sensor
23	common analogue inputs
24	remote display connection (-)
25	remote display connection (+)

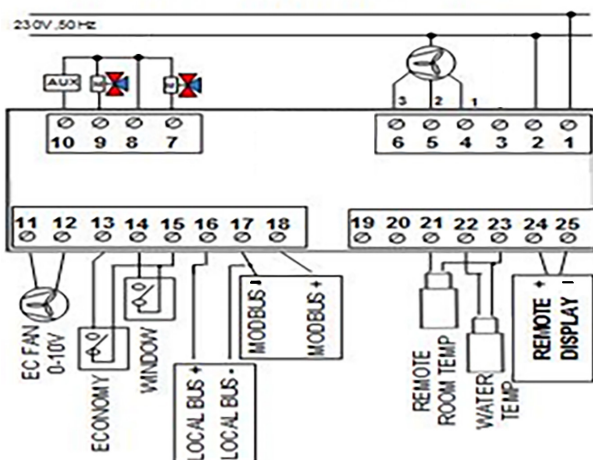

Terminal	Connection
1	phase power supply
2	neutral power supply
3	common phase for fan outputs
4	fan-speed 1, TRIAC 230 V, 1,25 A
5	fan-speed 2, TRIAC 230 V, 1,25 A
6	fan-speed 3, TRIAC 230 V, 1,25 A
7	auxiliary output TRIAC 0,8 A
8	heating valve actuator (open) TRIAC 0,8 A
9	heating valve actuator (close) TRIAC 0,8 A
10	common phase for actuators and aux output
11	cooling valve actuator (close) TRIAC 0,8 A
12	cooling valve actuator (open) TRIAC 0,8 A
13	remote display connection (+)
14	common (-) for local bus and remote display
15	local bus for slave controllers (+)
16	MODBUS output (-)
17	MODBUS output (+)
18	eco digital input, setpoint reduction
19	window digital input / shutdown
20	common input
21	analogue input water temperature sensor
22	analogue input for remote room sensor
23	0 ... 10 V DC output for fan (-)
24	0 ... 10 V DC output for fan (+)

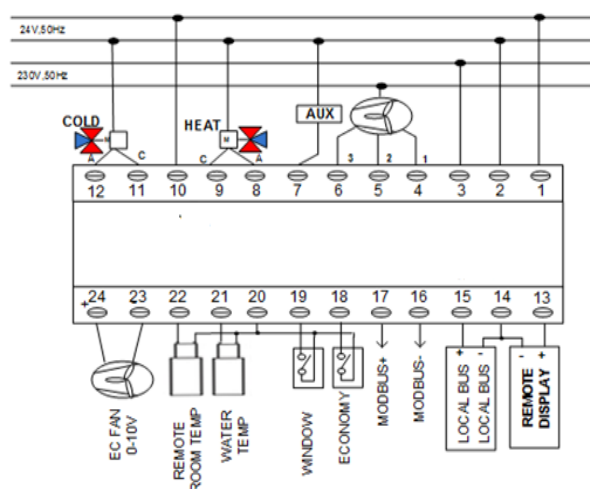

Dimensions

RTA50: 135 x 78 x 42 mm. External depth of the 503 box: 14 mm
 RTA51 controller without display for DIN rail mounting: 70 x 85 x 61 mm (2 modules)

